

MANUALE D'INSTALLAZIONE USO E MANUTENZIONE  
MANUEL D'INSTALLATION, UTILISATION ET D'ENTRETIEN  
INSTALLATION, USE AND MAINTENANCE MANUAL  
INSTALLATIONS, BETRIEBS- UND INSTANDHALTUNGSANLEITUNG  
MANUAL DE INSTALACIÓN USO Y MANTENIMIENTO  
MANUAL DE INSTALACIÓN USO Y MANTENIMIENTO

# eCool ED



IT - RADIATORI SCALDA-SALVIETTE ELETTRICI A FLUIDO TERMOVETTORE  
FR - RADIATEURS SÈCHE-SERVIETTES ÉLECTRIQUES À FLUIDE CALOPORTEUR  
EN - THERMAL VECTOR FLUID-FILLED ELECTRICAL TOWEL RAIL RADIATORS  
DE - ELEKTRISCHE HANDTUCHWÄRMER MIT WÄRMETRAGENDER FLÜSSIGKEIT  
ES - RADIADORES TOALLEROS ELÉCTRICOS DE FLUIDO PORTADOR DE CALOR  
PT - RADIADORES TOALHEIROS ELÉTRICOS DE FLUIDO TERMOVETOR

MULTI

fondital

CE

# INSTALLATION, USE AND MAINTENANCE MANUAL

## eCool ED

Dear Customer,



we thank you for your confidence. Before installing and/or using the product, please read carefully this manual concerning the correct installation, use and maintenance of the appliance.

We remind you as well that this manual must accompany the radiator in case of transfer to another place of installation.

### THE PACKAGE INCLUDES:

Aluminium towel rail radiator provided with electronic thermostat, kit composed of three shelves and relevant wall blocks, instruction manual.

### TABLE OF CONTENTS

1. WARNINGS .....	Page 31
2. ELECTRICAL CONNECTIONS .....	Page 32
2.1 Details on installation concerning the bathroom .....	Page 32
3. INSTALLATION OF THE APPLIANCE .....	Page 33
3.1 Radiator wall mounting .....	Page 33
4. ADJUSTMENT AND PROGRAMMING .....	Page 36
4.1 Control panel .....	Page 36
4.2 User functions.....	Page 37
4.2.1 Description of functions .....	Page 38
4.3 Use of the radiator .....	Page 40
4.3.1 Setting of current day and time.....	Page 40
4.3.2 Programming .....	Page 40
4.4 Remote control (optional) .....	Page 41
5. RADIATOR CLEANING .....	Page 41
6. FAILURES .....	Page 41
7. WARRANTY.....	Page 41
8. ENVIRONMENT .....	Page 42
9. CHARACTERISTICS OF THE APPLIANCE.....	Page 42
10. DECLARATION OF CONFORMITY .....	Page 43

## 1. WARNINGS

The radiator shall in **no** case:

- be in direct contact or too close to curtains, furniture, etc.

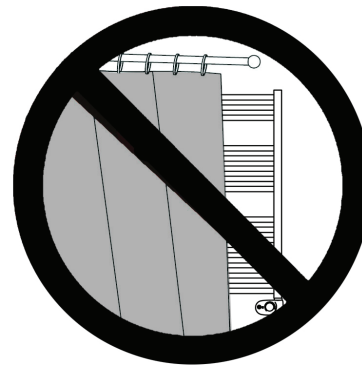

The radiator shall in no case be installed:

- in a niche
- at less than 10 cm from room corners
- under a power outlet
- above a shelf.

The radiator must be fixed to a wall through the supporting brackets provided with the product.

Interventions on the appliance must be carried out by a qualified professional.

Reparations that require to open the fluid tank must be carried out by the manufacturer, its agents or the customer service.



**WARNING: some components of this product may become very hot and burn. Pay particular attention in the presence of children or disabled people.**

Children under the age of 3 must be kept away from the appliance unless they are supervised.



Children aged between 3 and 8 can only turn the radiator on or off, provided that it is positioned properly and that children have been taught the safe use of the appliance and have understood the possible correlated risks.

Children aged between 3 and 8 cannot connect the appliance to the power outlet, cannot adjust or clean the appliance, and cannot carry out any kind of maintenance.

The appliance can be used by children aged no less than 8 and by persons with reduced physical, sensory or mental capabilities, or who do not have proper experience and knowledge, provided that they are supervised or they have been instructed on safe use of the appliance and have understood the inherent risks.



Do not allow children to play with the appliance.

**WARNING: In order to avoid a hazard for very young children, this appliance should be installed so that the lowest heated rail is at least 600 mm above the floor.**

Cleaning and maintenance intended to be carried out by the user shall not be performed by unattended children.

## 2. ELECTRICAL CONNECTIONS



### IMPORTANT

During installation, maintenance and cleaning, the appliance must not be powered.

The appliance must be powered only with 230 Vac voltage.

It is compulsory to install a multipolar switching device. The minimum separation distance between contacts shall be at least 3 mm.

It is compulsory that the power supply circuit of the appliance is protected by a **high sensitivity differential protection device**.

Do not insert metallic objects in or try to penetrate the plastic casing of the adjustment electronics.

If the power cable is damaged, it must be replaced only by a qualified electrician.

### 2.1. DETAILS ON INSTALLATION CONCERNING THE BATHROOM

Installation must be compliant with the standards and laws in force in the country of installation.

The radiator is in class II and with IP44 electrical protection. In the bathroom, it can be installed in areas 2 and 3 (see figure no.1) only if the control device cannot be touched by people that are using the shower or the bath.

The radiator is equipped with class 2 electrical insulation, it must not be connected to the ground wire.



**In the bathroom, protect the power line with a high sensitivity 30 mA differential protection device**

**Install a multipolar switching device. The minimum separation distance between contacts shall be at least 3 mm.**

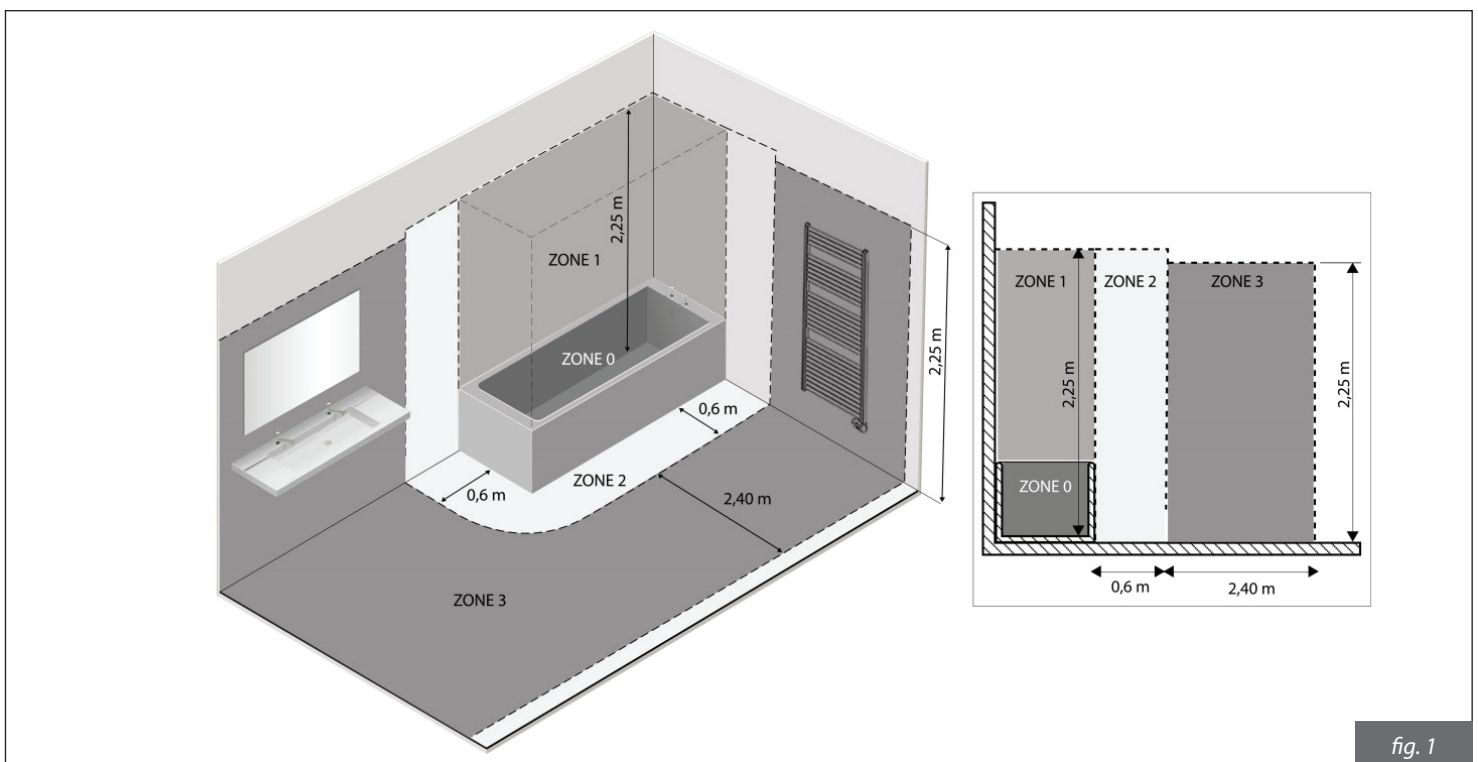

### 3. INSTALLATION OF THE APPLIANCE

The radiator must not be installed in a niche or under a power outlet.

Curtains, furniture or other objects that may obstruct the correct heat distribution must be placed at a minimum distance of 50 cm from the front of the radiator.

**WARNING: In order to avoid a hazard for very young children, this appliance should be installed so that the lowest heated rail is at least 600 mm above the floor.**

#### 3.1. RADIATOR WALL MOUNTING

The radiator must be fastened to a wall through the suitable mounting brackets provided with the product. The fastening system is composed of:

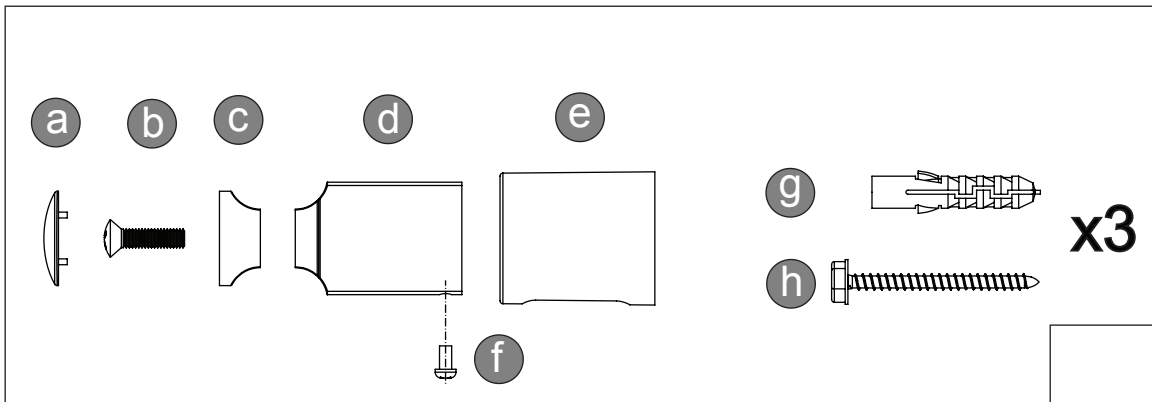

For wall mounting, please follow the indications below:

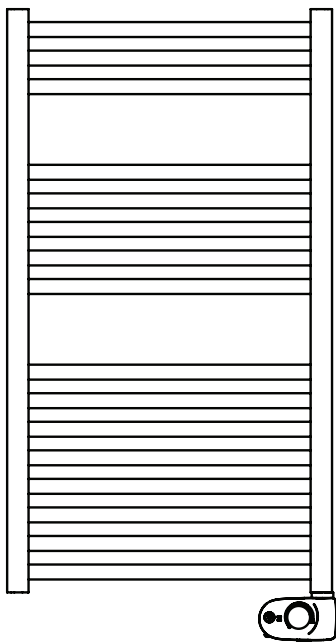

**OK**

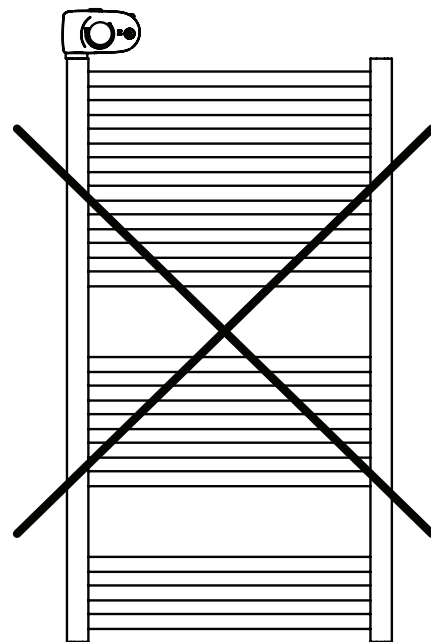

**NO**

	Radiator Model			
	300 W	500 W	700 W	1000 W
DIMENSION <b>L</b>	484	534	534	634
DIMENSION <b>L1</b>	478	528	528	628
DIMENSION <b>L2</b>	318	368	368	468
DIMENSION <b>L3</b>	159	184	184	234
DIMENSION <b>H</b>	933	1143	1563	1815
DIMENSION <b>H1</b>	672	882	1302	1554

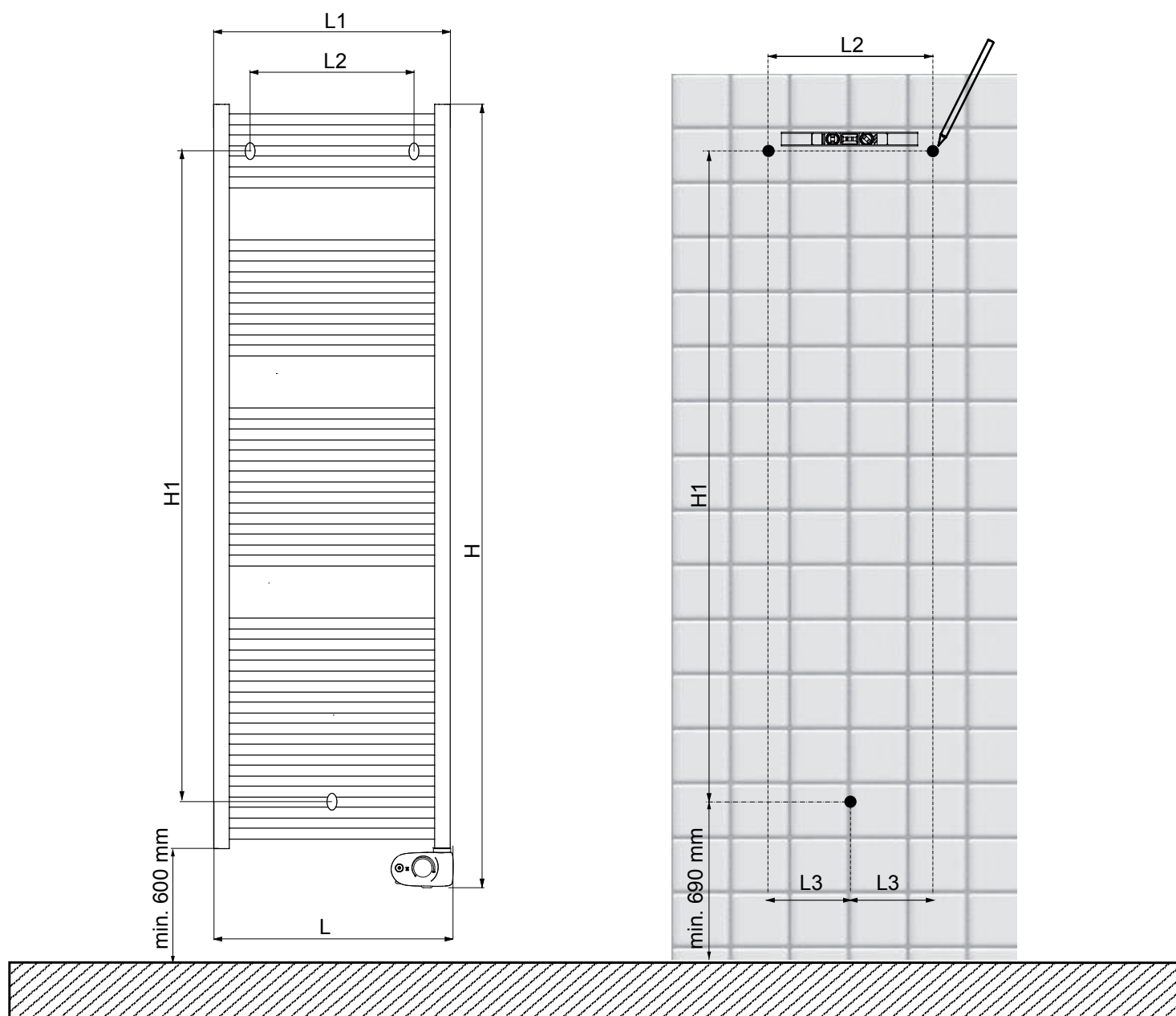
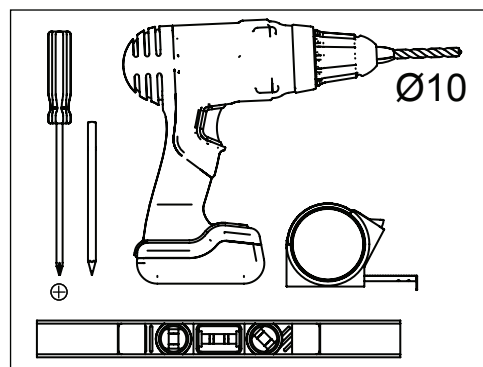

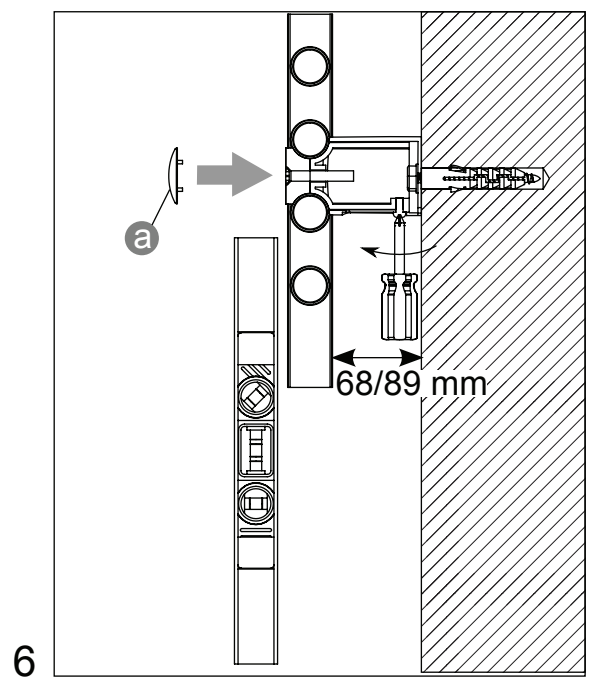
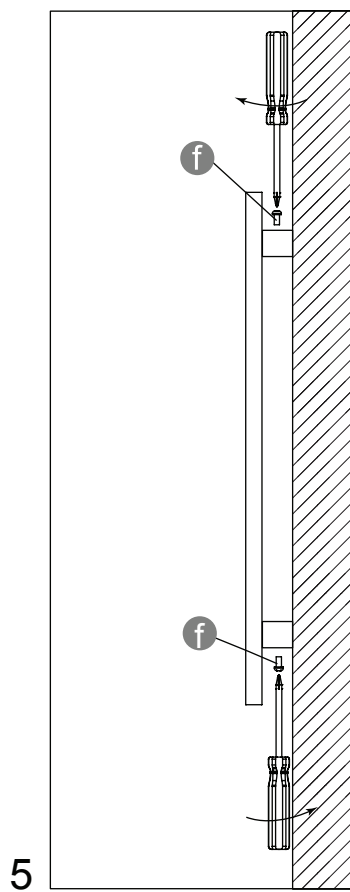
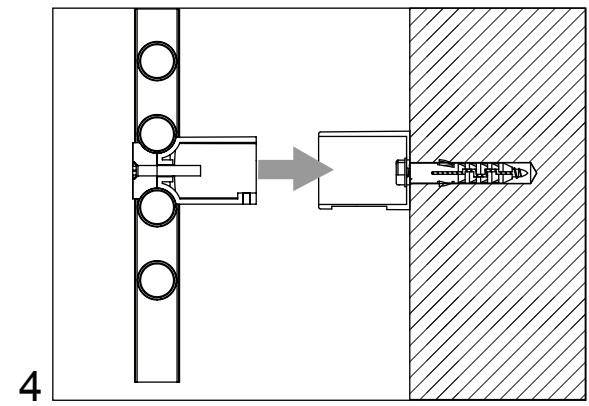
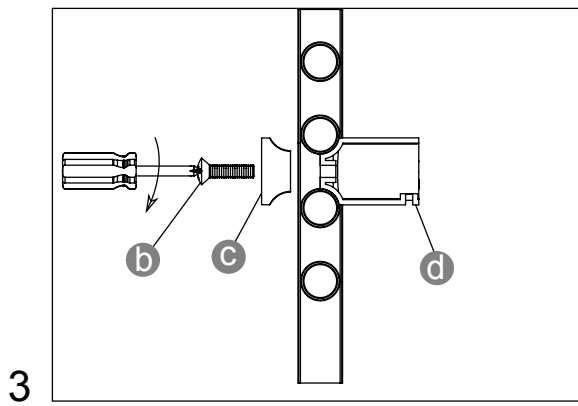
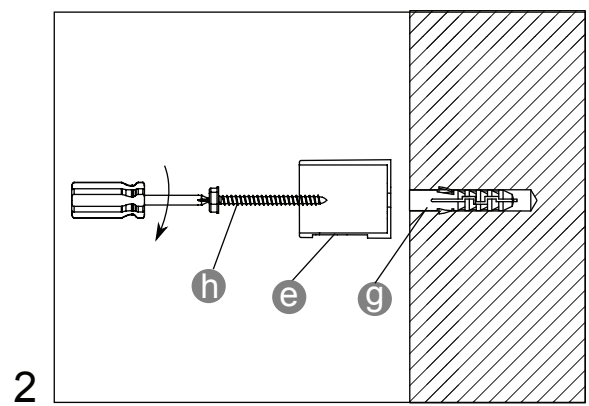
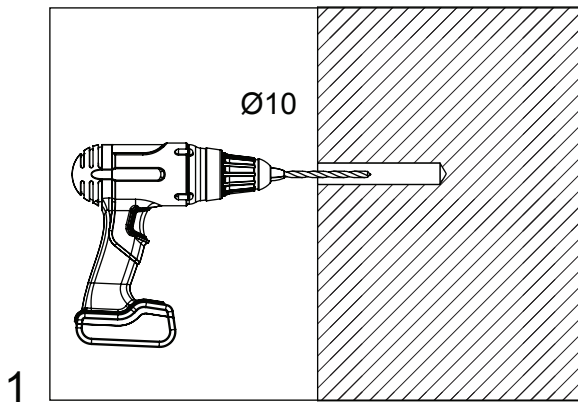

## 4. ADJUSTMENT AND PROGRAMMING

### 4.1. CONTROL PANEL

The electronics of the radiator is provided with a probe to detect the ambient temperature; this value is used as a basis to adjust the temperature according to the user's request.

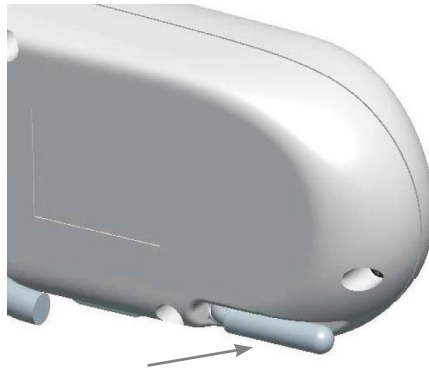

The electronics has an on/standby switch, an operating mode selection key and two + and - selection keys.

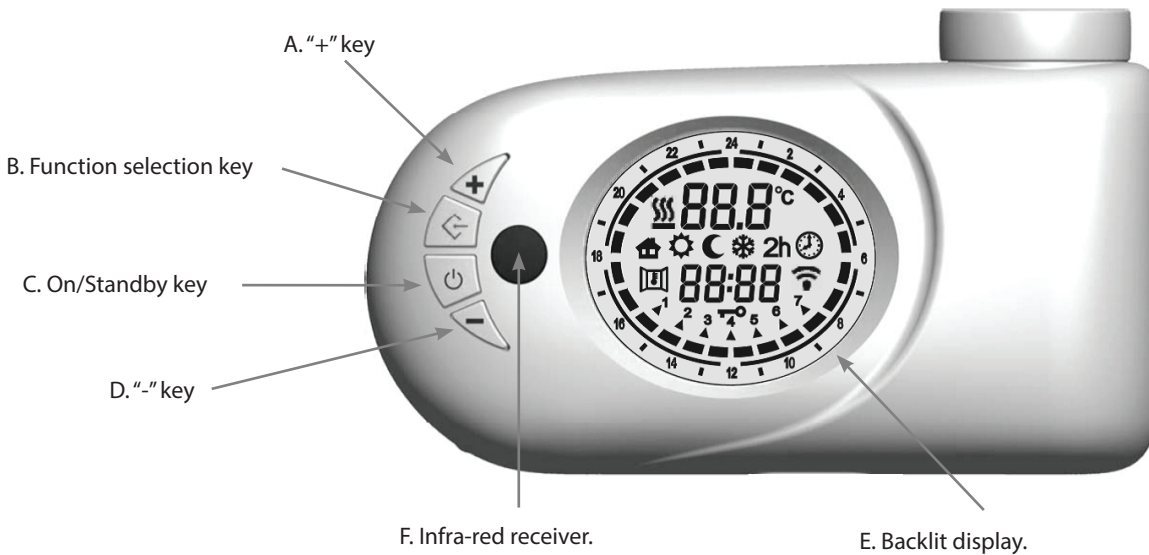

The display contains the icons shown below, and they are switched on from time to time according to the state of the radiator:

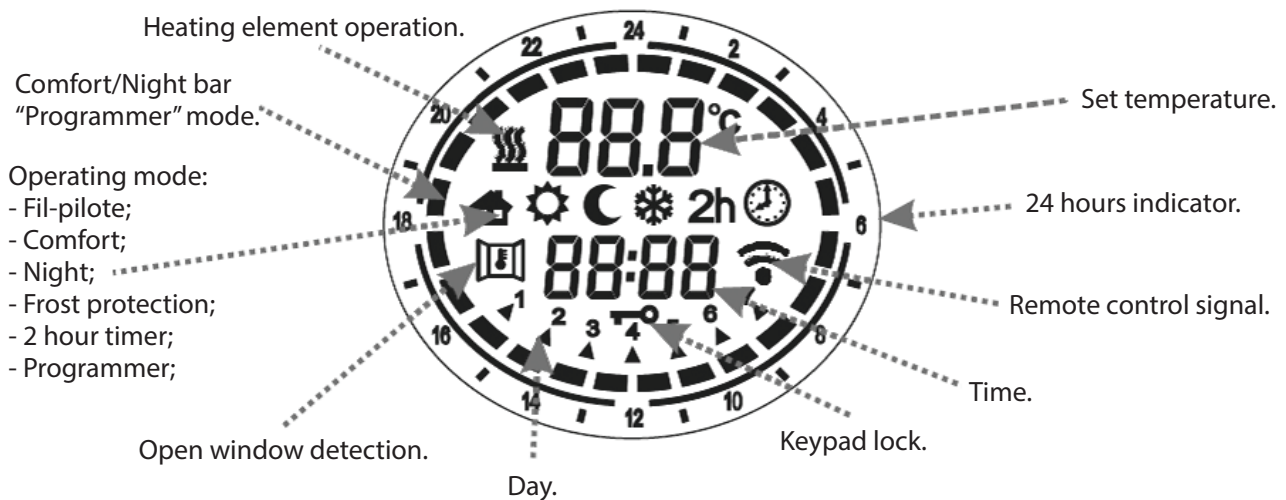



The electronics is also provided with an infra-red receiver (F) and can also be managed using a remote control that can be separately purchased as an accessory.







## 4.2. USER FUNCTIONS

This radiator is equipped with several functions and operating modes that the user can select through the B function key.



The radiator is equipped with the following user functions:

- Comfort
- Eco (night)
- Boost
- Programming
- Freeze protection
- Standby
- Pilot wire (not active on this model).

The icons corresponding to these functions and present on the display are the following:

					
Pilot Wire	Comfort	Eco (night)	Freeze protection	Boost	Programming

Moreover, the following special functions are also available:

Window opening function	
Key lock function	

## 4.2.1. DESCRIPTION OF FUNCTIONS

### Comfort Mode:

It is the standard mode of use of the radiator to keep the ambient temperature to the value set.

1. Press the function key until the relevant key is displayed.
2. Select the desired temperature using + and - keys

Note: Comfort temperature will always be 0.5°C higher than night temperature. It is not possible to set the Comfort temperature equal to or lower than the night temperature.

### Eco (night) mode:

By selecting this operating mode, the appliance keeps the ambient to the night temperature set. The desired night temperature setting takes place as follows:

1. Press the function key until the relevant key is displayed.
2. Select the night temperature using + and - keys.

Note: night temperature will always be 0.5°C lower than comfort temperature. It is not possible to set the night temperature equal to or higher than the comfort temperature.

### Boost Mode:

The radiator works at full power for 2 hours, regardless of the ambient temperature. At the end of the two hours, the radiator switches back to the previously selected operating mode. This mode is useful for quickly heating the rooms.

To set this mode, press the function key until the relevant "2h" icon is displayed.

### Programming mode:

In this mode the radiator works by automatically switching to Comfort or night mode following the daily/weekly settings programmed by the user.

To set this mode, press the function key until the relevant icon is displayed.

For the weekly programming refer to the suitable section of the manual.

### Freeze protection mode:

By selecting this mode, the ambient temperature is set to 7°C.  
Press the function key until the relevant key is displayed.

### Stand-by mode:

Press C key to switch on the appliance or to activate the "Standby" mode.  
In "Stand-by" mode the radiator is switched off, waiting for other commands.

NOTE: When appliance is in "Standby" mode, system will sound 2 acoustic signals for 0.5 seconds. When the appliance is switched on, system will sound one acoustic signal for one second.

When the appliance is in standby, it will display "Stb", the current time and day of the week.



**Warning:** in this position the radiator is still powered.

**Pilot wire mode** (not active on this model).

In this mode the radiator is controlled by a remote control unit.

## Window opening function

The radiator is able to identify whether a window has been opened through detection of a quick ambient temperature reduction (at least 1.5°C). If this happens, the radiator will switch off for 30 minutes; after this time has elapsed, the radiator will resume operation in the previously set mode.

When the function is activated the symbol of the window is displayed.

When the function is activated and detected at window opening, the displayed symbol of the window is intermittent.

When the function is deactivated the symbol of the window is not displayed.

The user can activate or deactivate this function as follows:

1. Switch the radiator to standby state.
2. Press "+" key for more than 3 seconds.
3. The symbol of the window is flashing. Press "+" key to activate (on) or deactivate (off) the function.
4. Press the function key to confirm your selection and go back to standby mode.

Window opening function activated:

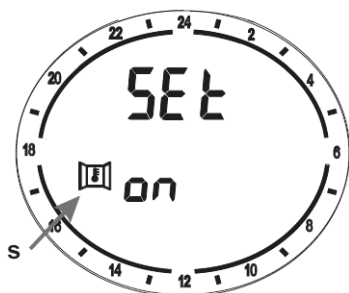

Window opening function not activated:

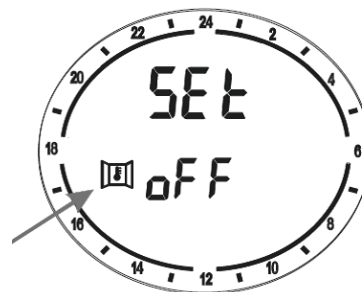

**Note:** the correct operation of this function depends on the radiator position. If the radiator is positioned in a way that does not allow the detection of the temperature reduction or where it can be affected by other heat sources, it is possible that the window opening will not be detected.

## Key lock function

It is possible to lock the device to avoid an improper or unintentional use, for instance for children protection or in a public space.

To lock/unlock the keys, press the B function key for three seconds, the keypad will be locked/unlocked in the required position.

When keypad is locked, the "+", "-" and function keys are not active. However, it is always possible to switch from ON to Standby mode and vice versa even with keypad locked, as the lock does not affect the on/standby key.



### 4.3. USE OF THE RADIATOR

Press the on/standby C key to switch the appliance on/off.

Warning: when the appliance is in standby mode it is anyway powered.

Note: in case of blackout the programming will remain memorised. If the blackout lasts less than 4 minutes, the date and time remain memorised and the programming will not be affected.

Note: the icon  indicates that a signal was received from the remote control (optional). It is possible to select the operating mode among those described above using "Function" key. For instance, if the comfort mode temperature is at 20.5°C and the day selected is Tuesday (day 2), the following icons will be displayed:



showing: set temperature, operating mode, time, number of the day of the week.

#### 4.3.1. SETTING OF CURRENT DAY AND TIME

1. Switch the radiator to standby state.
2. Press "-" key and hold it for 3 seconds, the display will show "Set".
3. Use "+" key to select "tEd".
4. When "tEd" is displayed, press function key to confirm your selection.
5. Select the day of the week among 1 (Monday), 2 (Tuesday),... and 7 (Sunday) using "+" and "-" keys.
6. Press function key to confirm your selection.
7. Now the current time is displayed and the figures indicating the time are flashing; time can be set using "+" and "-" keys.
8. Press function key to confirm your selection.
9. The figures indicating minutes are flashing; minutes can be set using "+" and "-" keys.
10. Press function key to confirm your selection, the radiator goes back to standby mode.

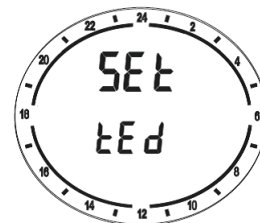

Note: in case of blackout date and time will remain memorised for about 4 minutes.

#### 4.3.2. PROGRAMMING

1. Switch the radiator to standby state.
2. Press "+" key for more than 3 seconds, "Set" will be displayed.
3. Use "+" key to select "Prog".
4. When "Prog" is displayed, press function key to confirm your selection.
5. Use "+" and "-" keys for each hour of the day, to select the comfort temperature (full bar in the lower part of the display) or the night temperature (short bar in the lower part of the display) of day 1 (Monday).

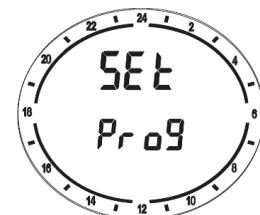

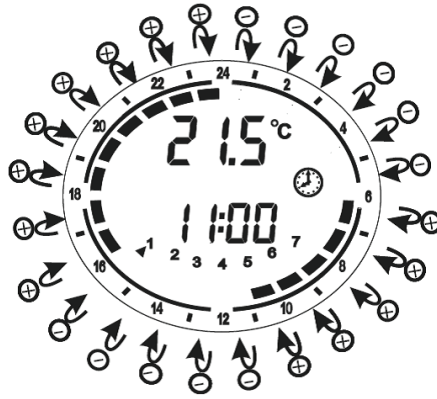

6. Press the function key to confirm the programming selection of the first day (day 1, Monday)
7. Repeat the same procedure for programming the remaining days from 2 to 7. Press only the function key to copy the same programming of one day to the following day.

#### **4.4. REMOTE CONTROL (optional accessory).**

The electronics is equipped with an infra-red receiver and can therefore be managed by means of a remote control that can be separately purchased as an accessory. All the above-mentioned functions can also be managed from the remote control.

### **5. CLEANING OF THE RADIATOR**

For your safety, before any cleaning operation, disconnect power supply  
Cleaning operations must be carried out with radiator off and cold.

Do not use abrasive or corrosive products to clean the heating body. Use, for instance, soapy water and then dry the body using a soft cloth.

Use only a dry cloth to clean the plastic parts and avoid contact with chemicals or alcohol.

### **6. FAILURES**

In case of failure do not use the appliance, disconnect it from power supply and for the repair address only to a technician approved and authorised to operate on this product.

Reparations that require to open the fluid tank must be carried out by the manufacturer, its agents or the customer service.

The manufacturer shall not be held responsible for damage to people, animals, or property due to tampering with or improper intervention to the radiator.

### **7. WARRANTY**

The body in aluminium alloy is warranted against manufacturing defects for 5 years from date of purchase. Electric and electronic components are warranted for 2 years from the date of purchase of the radiator. To validate your warranty, it is necessary to produce a document attesting the date of purchase (tax receipt, invoice, sales receipt).



For the validity of the warranty, the installation must comply with regulations and laws in force and must be carried out in accordance with best practices.

Warranty does not cover components subject to standard wear or consumption, as well as damages resulting from transport or assembly.

## 8. ROOM



The symbol applied to the appliance and shown here indicates that the product must be disposed of in separate collection for electrical equipment.

At the end of the life of the appliance, it cannot be eliminated as solid urban waste, but it must be sent to the collection centre of your area or returned to the dealer when buying a new appliance of the same type and destined to the same purpose.

Electrical and electronic equipment separate collection forms a part of a safeguard, protection and improvement policy of environmental quality and avoids potential harmful effects on human health due to the presence of harmful substances, according to the classification of the applicable European directives.

**Warning!** Incorrect disposal of the appliance involves sanctions.

## 9. CHARACTERISTICS OF THE APPLIANCE

 **IP44:** appliance protected against jets of water

**Class II:** double insulation

The radiator consists of a body in aluminium alloy and contains a fluid for internal heat transmission, composed of a mix of water and anti-freeze, specific for aluminium radiators. The internal fluid is heated through a resistor with class II insulation, a self-adjusting PTC resistor.

**Note:** during cold starting the power absorbed by the resistor during the first 2-3 seconds of operation is 50% higher than the typical power value. Control and adjustment electronics ensures the ambient temperature setting. Colour of the radiator: RAL 9010.

Input voltage	220 - 230 V AC 50/60 Hz	
Steady resistor power	Mod. eCool ED 300 W	300 W
	Mod. eCool ED 500 W	500 W
	Mod. eCool ED 700 W	700 W
	Mod. eCool ED 1000 W	1000 W
Insulation class	Class II	
Water protection class	IP44	
Working temperature	-5 ÷ 50 °C	
Storage temperature	-9 ÷ 70 °C	
Working relative humidity	0 ÷ 85 % non-condensing	
Temperature setting	Analogue setting with knob	
Temperature range	7°C ÷ 32°C	

Information requirements for electric local space heaters in accordance with Annex II, point 3.a.i.2, of the Regulation (EU) 2015/1188 of 28 April 2015 implementing Directive 2009/125/EC.

Model identifiers: <b>eCool ED 300W/500W/700W/1000W</b>					
Item	Symbol	Value	Unit	Item	Unit
<b>Heat output</b>				<b>Type of heat output/room temperature control</b>	
Nominal heat output	P <sub>nom</sub>	0,3 /0,5/0,7/1	kW	single stage heat output and no room temperature control	no
Minimum heat output (indicative)	P <sub>min</sub>	N.A.	kW	Two or more manual stages, no room temperature control	no
Maximum continuous heat output	P <sub>max,c</sub>	0,3 /0,5/0,7/1	kW	with mechanic thermostat room temperature control	no
<b>Auxiliary electricity consumption</b>				with electronic room temperature control	no
At nominal heat output	el <sub>max</sub>	0,3 /0,5/0,7/1	kW	electronic room temperature control plus day timer	no
At minimum heat output	el <sub>min</sub>	n.d.	kW	electronic room temperature control plus week timer	yes
In standby mode	e <sub>LSB</sub>	0,369	W	<b>Other control options</b>	
				room temperature control, with presence detection	no
				room temperature control, with open window detection	yes
				with distance control option	no
				with adaptive start control	no
				with working time limitation	no
				with black bulb sensor	no
Contact details	<b>Fondital S.p.A.</b> 25079 VOBARNO (Brescia) Italy - Via Cerreto, 40 Tel. +39 0365/878.31 - Fax +39 0365/878.304 e mail: info@fondital.it - www.fondital.com				

## DECLARATION OF CONFORMITY

We hereby declare for

**FONDITAL S.p.A.**  
with registered office in  
Via Cerreto 40, 25079 Vobarno (BS) Italia

that

### ELECTRICAL RADIATORS FOR HEATING PURPOSE

Model

**eCool ED\_**

**produced by FONDITAL S.p.A.**

are manufactured according to European directives and European regulations:

- Directive 2014/35/CE: "Low Voltage"
- Directive 2014/30/CE: "Electromagnetic Compatibility"
- Directive 2012/19/CE: "WEEE"
- Directive 2009/125/EC: "Eco-design"
- Directive 2011/65/CE: "ROHS"
- Regulation (EU) 2015/1188

and in accordance with rules:

EN 60335-1:2012  
EN 60335-2-43:2005+A1:2006+A2:2009  
EN 55014-1:2008  
EN 55014-2:1998  
EN 61000-3-2:2004  
EN 61000-3-3:2004

EN 61000-4-2:2009  
EN 61000-4-4:2005  
EN 61000-4-5:2006  
EN 61000-4-6:2009  
EN 61000-4-11:2004  
EN 62233: 2008

**FONDITAL S.p.A.**  
In the Direction's stead  
The manager of Technical Office  
eng. Roberto Cavallini



Vobarno, date of issue or of postal mark

Dichiarazione di conformità  
radiatori elettrici

eCool ED\_ Edizione 1 del 11 novembre 2015