

# ACTUATOR SERIES ARD200

ESBE Actuator Series ARD200 is a spring return rotary actuator with 20Nm torque and an operating range of 90° suitable for the ESBE mixing valves DN100-150. The ARD200 can also be used as damper actuator for dampers up to 4 m². The actuators is available in 24V AC/DC or 230V AC/DC versions with 2-point or proportional control signal.

## APPLICATION

The ESBE series ARD200 is a spring return actuator suitable for both rotary mixing valves as well as damper applications.

Thanks to the high torque the ARD200 is suitable to work with the largest ESBE valve DN100-150 and with dampers sizes up to 4m². The actuator comes with 2 sets of adapters, one set for assembly on ESBE valves 3F/4F and one set with clamp coupling for damper spindle assembly.

## VERSIONS

The series consist of 3 different versions:

- ARD255 with 2-point control signal, 230V AC/DC power supply and 1m preassembled cable.
- ARD257 with 2-point control signal, 24V AC/DC power supply and 1m preassembled cable.
- ARD269 with proportional control signal (0-10V, 2-10V, 0-20mA, 4-20mA), 24V AC/DC power supply and 1m preassembled cable. The version has a 0(2)-10V feedback signal based on the real position.

All versions have a spring return function that moves the actuator to closed position in case of power failure. The direction of rotation is selected by the mounting side of the actuator, see further information in chapter Settings. All versions can be manually operated when the power supply is switched off. A lever, to be used when manually opening and locking the actuator in the manual position, is attached to the cable. The manual position is kept until manually release or power supply is switched on.

Standard operating range is 90° but can be limited in the open position by easily adjusting the end-stop on the front of the cover. Proportional control signal and feedback signal will be adjusted to the new operating range when calibration/adaptation process is performed.



ARD200

## SUITABLE MIXING VALVES AND DAMPERS

Together with the valve assembly kit the ARD200 is easily mounted on the ESBE valve series 3F and 4F from size DN50 to DN150.

Together with damper assembly kit the ARD200 is easily mounted on square spindle with dimension 9...18 mm and round spindle with dimension 9...26 mm. ARD200 can be used on dampers up to 4m² but specifications supplied by the damper manufacturers (cross section, design, installation site) and the air flow conditions must be observed.

### TECHNICAL DATA

Ambient temperature:	_____ max. +50°C
	_____ min. -30°C
Ambient humidity:	_____ 5...95% r.H. non-condensating
Power supply:	_____ 24V AC (50/60 Hz), 24V DC
	_____ 230V AC (50/60 Hz), 230V DC
Nominal voltage range:	_____ 19...29V AC/DC,
	_____ 85...265V AC/DC
Power consumption, running:	24V _____ 10.5 W
	230V _____ 10.5 W
Power consumption, standby:	24V _____ 2.5 W
	230V _____ 2 W
Wiring sizing:	24V _____ 14 VA
	230V _____ 22.5 VA
Enclosure rating:	_____ IP54
Protection class:	24V _____ III
	230V _____ II
Torque:	_____ 20Nm
Running time, opening (2-point):	_____ 75s/90°
	opening (proportional): _____ 150s/90°
	closing: _____ 20s/90°
Cable length:	_____ 1m
Weight:	_____ 2.4 kg

CE LVD 2014/35/EU  
EMC 2014/30/EU  
RoHS 2011/65/EU

# ACTUATOR SERIES ARD200

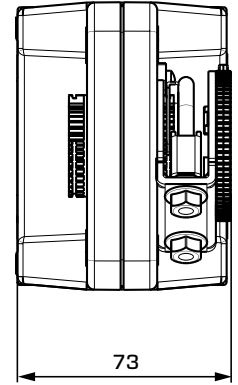
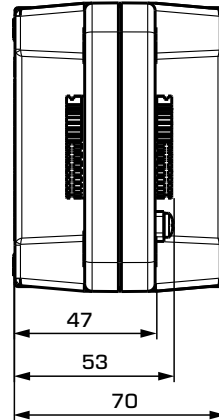
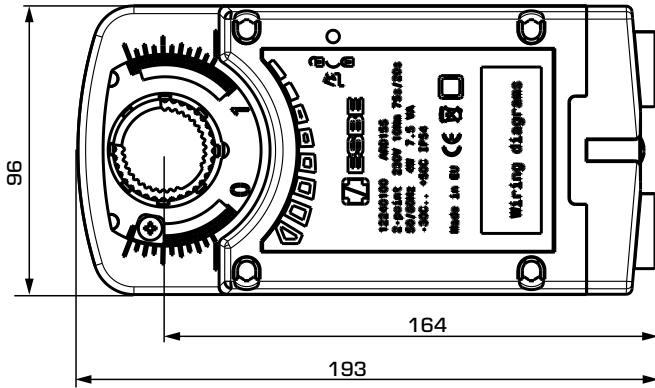

Actuator Series ARD200

Damper assembly kit

## SERIES ARD200

Art. No.	Reference	Voltage [V AC/DC]	Running time		Control signal	Torque [Nm]	Note
			opening 90° [s]	closing 90° [s]			
12240200	ARD255	230	75	20	2-point	20	
12241200	ARD257	24	75	20	2-point	20	
12260200	ARD269	24	150	20	Proportional*	20	

\* Proportional = 0-10 V, 2-10 V, 0-20 mA, 4-20 mA

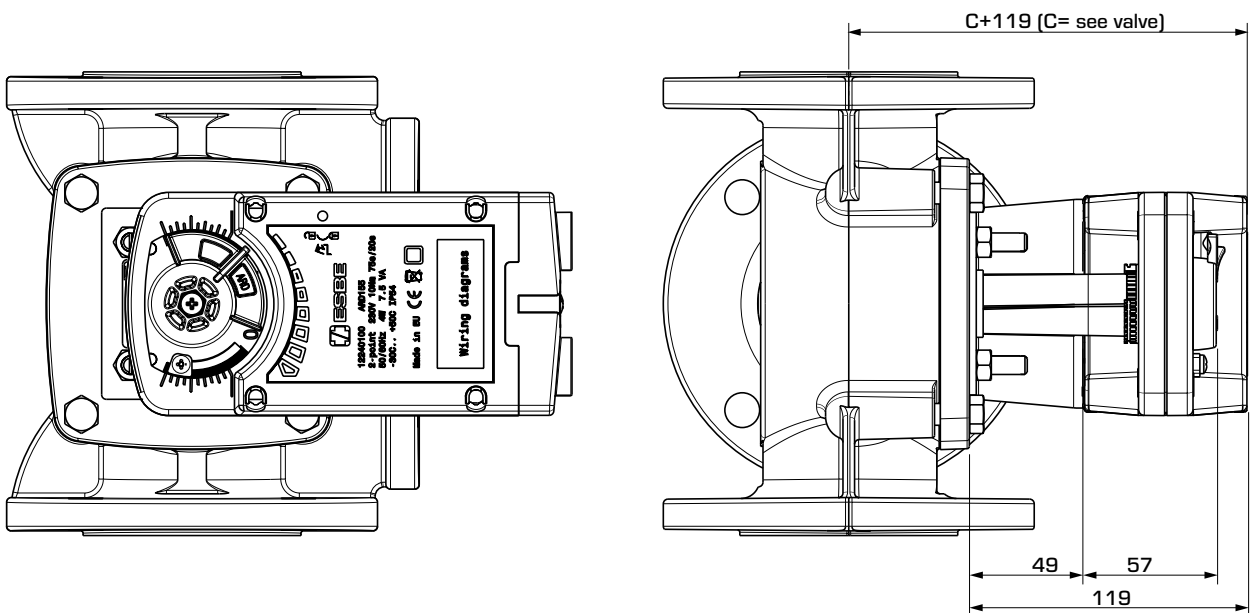

Installation dimensions for Actuator Series ARD200, with valve assembly kit

# ACTUATOR SERIES ARD200

## SETTINGS

Direction of rotation

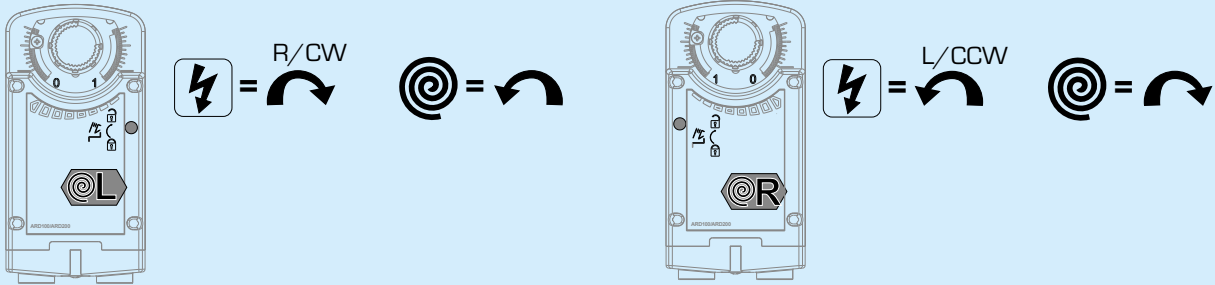

## WIRING

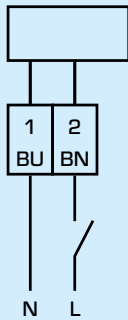

Electrical connection ARD255/ARD257 (2-point)

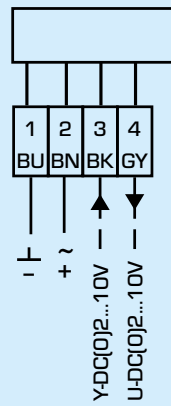

Electrical connection ARD269 (Proportional)